

4 Devices

[RMS-LOG-T30-L](#) ³⁷²

4.1 RMS-LOG-T30-L

The RMS-LOG-T30-L is a data logger with two integrated analogue digital converters (ADC) to which two PT100 sensors can be connected for high-precision temperature measurement. It has an Ethernet connection for integration into the Rotronic Monitoring System (RMS). The device is equipped with a battery, which ensures the recording of the measurement data even during an interruption of the external power supply.



[Step-by-Step](#) ³⁷²
[Dimensions](#) ³⁷⁴
[Device Description](#) ³⁷⁴
[Sensors](#) ³⁷⁵
[Housing](#) ³⁷⁸
[Basic Initialisation](#) ³⁸¹
[Customers adjustment](#) ³⁸⁴
[Maintenance](#) ³⁸⁴
[Modbus](#) ³⁸⁵
[SW Configuration](#) ³⁸⁶
[Technical Specification](#) ³⁸⁷
[Accessories](#) ³⁸⁸

4.1.1 Step-by-Step

Hardware Setup

Purchased parts package

Picture to place...

Battery

Picture to place...

See also [Basic Initialisation](#) 

Sensor connection

Picture to place...

Please consider the chapter [Sensors](#) 

Device power

Picture to place...

Please see the [Device Description](#) 

Mouting

Picture to place...

Please consider the chapter [Housing](#) 

System integration

Network Settings

Screenshots!

Still under construction!

Web Service Settings

Screenshots!

Still under construction!

Adjustement

Screenshots!

Still under construction!

Calibration

Screenshots!

Still under construction!

Device Properties

Screenshots!

Still under construction!

4.1.2 Dimensions

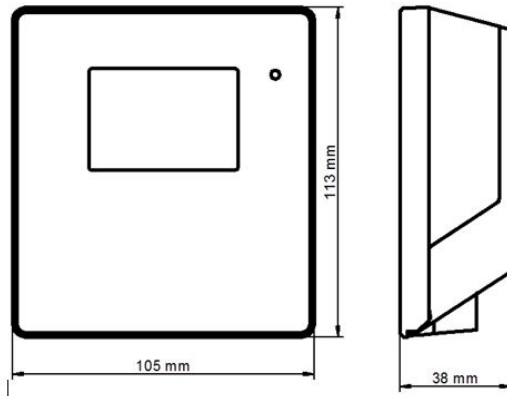

4.1.3 Device Description

Functions:

Functions	Description
Discovery	<ul style="list-style-type: none"> The Discovery function can be used to find and configure devices within the subnet regardless of their IP configuration.
Use of a static IP-Configuration	<ul style="list-style-type: none"> IP-Address Subnet Address Gateway Server
Use of dynamic IP-Address (DHCP)	<ul style="list-style-type: none"> DHCP Client can turned on / off.
URL of the RMS-WEB Service	<ul style="list-style-type: none"> Configuration of the URL for using the RMS-WEB Service.
DNS Server	<ul style="list-style-type: none"> For the DNS, a primary and secondary DNS address can be set.
Temperature Measurement	<ul style="list-style-type: none"> The measurement data are sent to the RMS-WEB software at the set interval. The device sends to the measured data via Modbus TCP to the RMS-WEB Service every set interval.
Logging function	<ul style="list-style-type: none"> Every measurement value and the time stamp is stored in the device memory. In case of data interruption, the data can be red out via the RMS-WEB software automatically afterwards.
Audit Trail	<ul style="list-style-type: none"> The device stores changes of the device settings.

	<ul style="list-style-type: none"> • These information are supplied to the RMS-WEB Service.
Battery powered operation	<ul style="list-style-type: none"> • If the external power supply fails, the device runs in battery mode. Measurements are still carried out in the specified interval and the data is stored in the memory.
Firmware Update	<ul style="list-style-type: none"> • The firmware update can be done by the RMS-WEB Service.

Power Variants:

Option 1: 24V, via terminal, see accessories

Option 2: Power over Ethernet (IEE 802.3af, Class 1)

Option 3: Battery, see RMS-BAT [RMS-BAT Rotronic Website](#)

 Power supply to be used: 24 VDC ±10%, 4 W nominal, < 15 W Limited Power Source

Logging function:

For each temperature measurement, the measured values are stored in the memory with the associated time stamp. At a measuring interval of one minute, data can be stored for one month, which corresponds to approx. 44,000 measurements. If the memory is full, the oldest values are overwritten

Indicator and Push-button:

The device has a button and a multi-coloured LED for operation and display of the operating status. The button is used when the device is put into operation or to switch off the logging process in battery mode. The LED indicates the device status and whether a valid measurement was performed in the current measurement interval and the data could be sent to the monitoring system.

4.1.4 Sensors

Measurement principal:

The device carries out a temperature measurement at an adjustable interval for each connected PT100 sensor, stores the values and, if possible, forwards them to the server.

The device has two integrated analog digital converters (ADC) for connecting two PT100 sensors. The PT100 can be connected to the ADC using 2-, 3- or 4-wire technology.

PT100 connections:

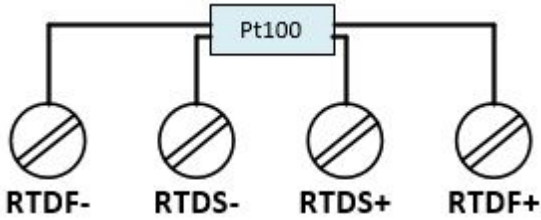
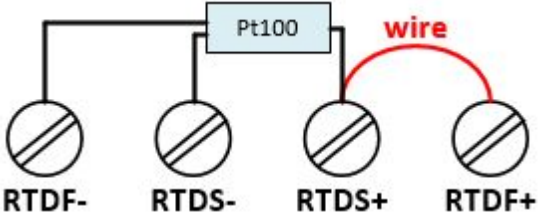
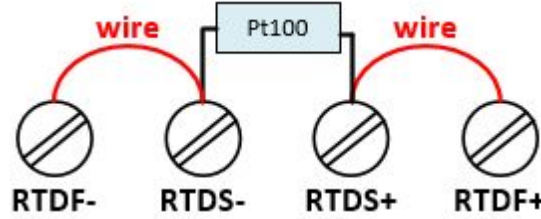
Connection	Description
4-wire technology	<p>The 4-wire technology provides by far the most accurate measurement results, it completely eliminates the influence of the connecting cables on the measurement result, since any differences in the cable resistances of the connecting cable are also compensated</p> 
3-wire technology	<p>The influence of the line resistance is largely compensated with a 3-conductor technology. The prerequisite for this, however, is that the line resistances are the same.</p> 
2-wire technology	<p>In 2-wire technology, the resistance of the supply lines to the sensor flows into the measurement as an error. The 2-wire technology therefore provides the most inaccurate measurement results of the 3 different connection techniques.</p> 

Temperature calculation:

The properties of a platinum resistance thermometer are defined in the IEC751 standard (Europe: EN60751). The current standard is EN60751+A2:1995 and is based on ITS90, the International Temperature Scale of 1990. According to this standard, a platinum resistance is converted into the corresponding temperature using the following formulas.

Temperature range	Formula
-200°C to 0°C	$R(T) = R_0 (1 + AT + BT^2 + C (T - 100^{\circ}\text{C}) T^3)$

Temperature range	Formula
0°C to 850°C	$R(T) = R_0 (1 + AT + BT^2)$
	R(T) currently measured resistance at a temperature T
	R0 => PT100 nominal resistance and is 100? at 0°C (ITS90)
Callendar van Dusen Coefficient	A = $3.9083 * 10^{-3} \text{ } ^\circ\text{C}^{-1}$
	B = $-5.775 * 10^{-7} \text{ } ^\circ\text{C}^{-2}$
	C = $-4.183 * 10^{-12} \text{ } ^\circ\text{C}^{-3}$

With these formulas and the corresponding calculation tables between -200°C and +850°C, each temperature can be calculated or interpolated for the respective measured PT100 resistance.

Example for a PT100 table: <https://www.omega.de/temperature/Z/pdf/z252-254-de.pdf>

For highly accurate PT100 measurements, the Callendar van Dusen coefficients can be adapted to the respective PT100 sensor.

Conversion of the resistance value into a temperature value:

With the formulas for temperature calculation described above, a table is calculated internally, which is used to convert the measured resistance value into the corresponding temperature. This table also takes into account the possible change in the Callendar van Dusen coefficients and is calculated for each change and each restart.

Description	Calculation
Temperature	$T(R) = T_{low} + ((R - I_{low}) * ((T_{high} - T_{low}) / (I_{high} - I_{low})))$
	R = currently measured resistance value (factory adjusted)
	I _{low} = next table value (index) lower than R _{Meas}
	I _{high} = next table value (index) that is higher than R _{Meas}
	T _{low} = To I _{low} related table value
	T _{high} = To I _{high} related table value

If the currently measured resistance is outside the table, the measurement is invalid.

Example of a resistance-temperature table:

Index ?	Temperature °C
185.200800	-200.0
270.964328	-180.0
...	...
1000.000000	0.0
...	...

Index ?	Temperature °C
3831.286563	825.0
3904.811250	850.0

4.1.5 Housing

Take out cover / wall holder

There is an opening in the mounting bracket on the top of the unit. Press it in slightly with a blunt object (e.g. the tip of a ballpoint pen). The flap pops open.



Fold down the cover to the rear and separate it from the base unit



The cover has 2 suspension openings and 2 additionally prepared fastening options.



Only the intended mounting points are to be used for mounting.

Placement of the device

Position the housing cover and press lightly on the housing cover until the lug is properly engaged.

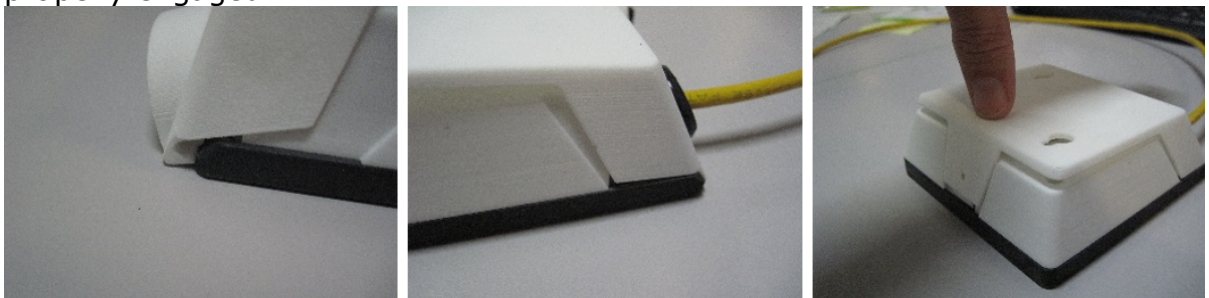

Mounting

The wall bracket is fastened to the wall with screws according to the drilling template.

The housing is inserted into the wall bracket and folded down, whereby it can be locked in place with pressure.

The following points must be observed in order to comply with protection class IP65:

- The screws must only protrude so far that the device can engage correctly when mounted on the screwed-on cover.
- The wall bracket must not be deformed by tightening the screws, otherwise IP protection cannot be guaranteed.

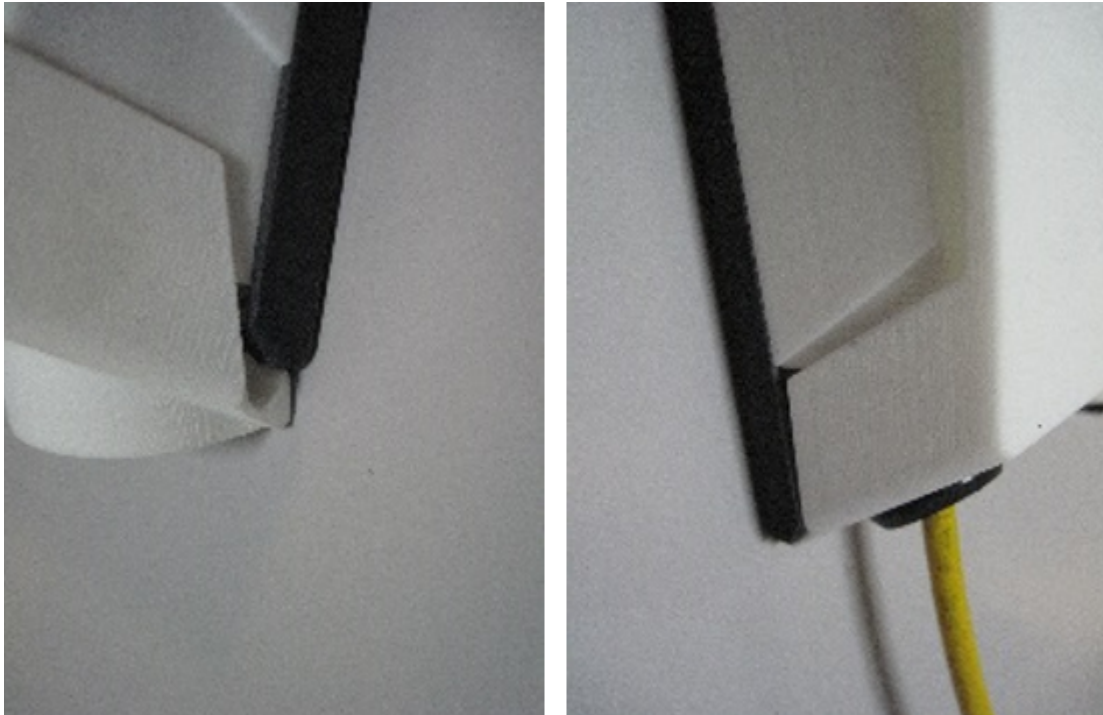

Screws:

Type: round-head screws
 Diameter d1: M3.5
 Head diameter d2: 7 mm
 Head thickness k: 2.5 mm
 Length L: 20 mm

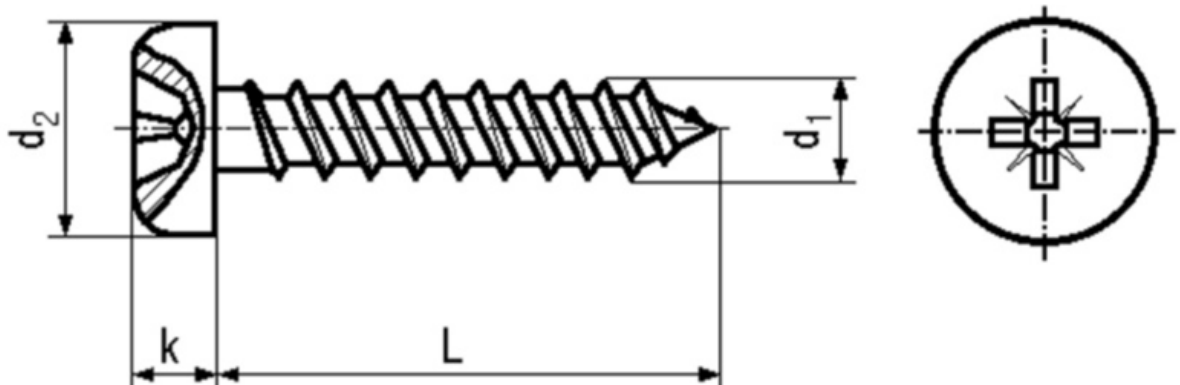

Drilling template Wall bracket

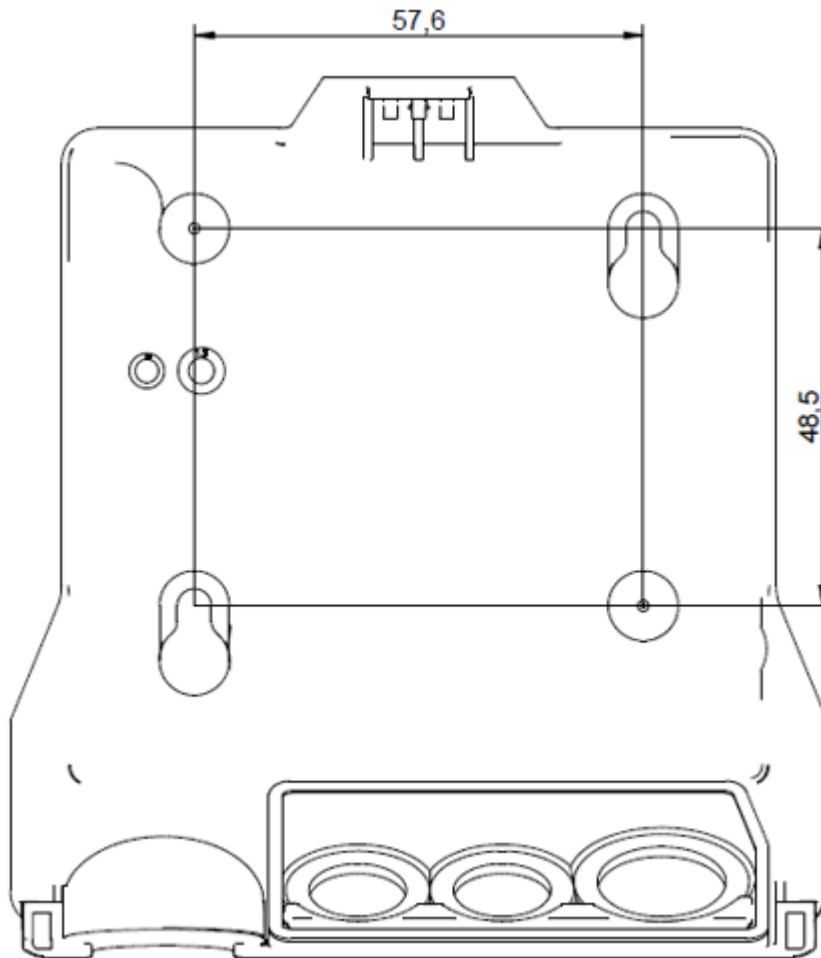

4.1.6 Basic Initialisation

Default settings

TCPIP Konfiguration: DHCP Server on; the configuration will be set automatically

RMS-WEB Server URL:

<http://rms.rotronic.com/wService/wService3.DeviceService.svc>

Network configuration

For different configuration that default, please use the RMS-CONFIG software.

- Searching for the device in the network (using the device search function)
- Adjusting the TCPIP settings for the device
- Customizing the Web Service URL

Pairing

For a successful pairing into the RMS, the device must have a valid Ethernet configuration and to reach the RMS-WEB server via HTTP (outgoing port 80)!

If the device has a valid Ethernet configuration and the RMS-WEB server can be reached, it can be integrated into the system by pairing:

- a) Start the pairing by adding the device via the serial number in the RMS-WEB software.
- b) If the pairing request has been received by the device, the LED Orange starts flashing. Confirming the pairing by pressing a button
- c) Completion of the pairing in the RMS-WEB software

Indicator LED

When powered externally, the LED flashes every five seconds to indicate the status of the unit. The displayed device status is updated with each measurement and therefore always refers to the last measurement.

In battery mode, the status can be set to be displayed less frequently or only at the touch of a button to extend the running time.

Blinking	Power	Details
1x Green	External supply or battery	Measurement successful, data transmission successful
1x Orange	External supply or battery	Measurement successful, data transmission failed
1x Red	Battery only	Low battery
2x Red	External supply or battery	Measurement not possible

Push-button

The device is controlled and configured via a server application. When a device is integrated into a system, a keypress must confirm that the user is the owner of the respective device.

Whether a device is integrated in the system is primarily stored on the server. However, the device retains this information each time it communicates with the server and maintains the state in the event of a reboot or loss of connection. To remove the device from the system, it must be deleted from the server.

With a long keystroke, the local copy of the state can be discarded. Please note that the next time you communicate with the server, the state stored on the server will be adopted (if the device is integrated into the system). The function can be used as follows:

- a) The device is in battery mode (no server communication) and should be temporarily deactivated (no measurement, recording).
- b) The device is connected to a system which is not accessible and should now contact another server. In the integrated state, write protection via ModbusTCP

is active, which prevents settings from being overwritten. By a long keystroke this is deactivated and the new configuration can be written.

Operation external powered

Operation status	Push-button pressed	
Pairing	Short time	Confirm pairing when connecting the device to the Rotronic Monitoring System. The LED flashes orange before the pairing can be confirmed. If the pairing is not confirmed, the device returns to offline mode after a certain time (determined by the RMS-WEB software).
Online	Long time (app. 4 to 5sec.)	Discard the local pairing information. Note that pairing is always set by the server. If there is a connection to the server, the pairing is immediately taken over again.

In all operation status not listed (in the table above), the push-button has no function.

Operation battery powered

Operation status	Push-button pressed	
Pairing	Short time	Display of the operation status by the LED indicator
Online	Long time (app. 4 to 5sec.)	Stop of the logging function, turn-off the device.

In all operation status not listed (in the table above), the push-button has no function.

Battery

After removing the wall bracket, insert the batteries according to the label in the battery compartment.

- The batteries are used to power the unit in the event of a failure of the external power supply. In battery operation, the functionality is limited and the device cannot be addressed via Ethernet.
- Lithium AA batteries with 3.6 V are used.
- The mounting position must be observed. The polarity is indicated on the battery and in the battery compartment.

4.1.7 Customers adjustment

General

The customer can compensate possible deviations of the temperature measurement by an own adjustment. The customer uses temperature values as reference points for his adjustment.

1-point adjustment

1-point adjustment corresponds to a offset over the whole measurement range.

	Calculation
Offset temperature	$T_{\text{Offset}} = T_{\text{Ref}} - T_{\text{Akt}}$
	T_{Ref} = reference temperature
	T_{Akt} = actual measured temperature (live from the device or noted by the customer)
End temperature	$T_{\text{End}} = T(R) + T_{\text{Offset}}$
	$T(R)$ = temperature (already corrected)

2-point adjustment

For the 2-point adjustment the customer can acquire two points.

	Calculation
Slope	$m = \frac{T_{\text{Ref2}} - T_{\text{Ref1}}}{T_{\text{Act2}} - T_{\text{Act1}}}$
Offset	$n = \frac{(T_{\text{Ref1}} * T_{\text{Act2}}) - (T_{\text{Ref2}} * T_{\text{Act1}})}{T_{\text{Act2}} - T_{\text{Act1}}}$
	T_{Ref1} = reference temperature 1
	T_{Ref2} = reference temperature 2
	T_{Akt1} = measured temperature 1 (live from the device or noted by the customer)
	T_{Akt2} = measured temperature 2 (live from the device or noted by the customer)
End temperature	$T_{\text{End}} = m * T(R) + n$
	$T(R)$ = temperature (already corrected)

4.1.8 Maintenance

Battery change

- Remove the wall bracket (see [Housing](#)^[378])
- Removing the old batteries
- press the key for a short moment. Remaining charge is consumed and a restart of the device is ensured.

- Insert the new batteries ([Basic Initialisation](#)³⁸¹)

FW update

The firmware can be updated with the RMS software.

4.1.9 Modbus

Modbus TCP Server

The device has a Modbus TCP server for direct connection to external devices. The data accessible via Modbus can be found in the table below.

	Details
Protocoll	Modbus TCP
TCP Port	502

Connection timeout

If no communication happens with an open TCP connection during 30 seconds , the connection is closed by the device. This prevents the socket from being blocked in the event of an interruption without a clean disconnection.

Function 04 – Read Input Register

Device Data

Register	Parameter		Datatype
30001	serial number		Unsigned 32 Bit
30002			
30003	serial number of the sensor		Unsigned 32 Bit
30004			

Float Values

Register	Parameter		Datatype
31001	Measurement value 1	Temperature value RTD 2	Float 32 Bit
31002			
31003	Measurement value 2	Temperature value RTD 2	Float 32 Bit
31004			

Integer Values

The temperature values are supplied only as float.

Float Swap Mode

Swap Mode is used to set how a Float32 is to be mapped to the Modbus data structure:

45 = 0x42340000
 1000 = 0x447A0000

NoChange (Big Endian)			Word Swap (Mixed Endian)		
31001	16948	0x4234	31001	0	0x0000
31002	0	0x0000	31002	16948	0x4234
31003	17530	0x447A	31003	0	0x0000
31004	0	0x0000	31004	17530	0x447A
Byte Swap (Middle Endian)			Byte and Word Swap (Little Endian)		
31001	13378	0x3442	31001	0	0x0000
31002	0	0x0000	31002	13378	0x3442
31003	31300	0x7A44	31003	0	0x0000
31004	0	0x0000	31004	31300	0x7A44

4.1.10 SW Configuration

Network Settings

Screenshots!
 Still under construction!

Web Service Settings

Screenshots!
 Still under construction!

Adjustement

Screenshots!
 Still under construction!

Calibration

Screenshots!
 Still under construction!

Device Properties

Screenshots!
 Still under construction!

4.1.11 Technical Specification

Connectors



Pin	Description	Function
1	V+	Power Supply +
2	V-	Power Supply -
3	1F+	RTD 1 Force+
4	1S+	RTD 1 Sensor+
5	1S-	RTD 1 Sensor-
6	1F-	RTD 1 Force-
7	2F+	RTD 2 Force+
8	2S+	RTD 2 Sensor+
9	2S-	RTD 2 Sensor-
10	2F-	RTD 2 Force-

 Before switching on the 24V supply, check that the plug is inserted in the correct position. If this is not the case, the device can be damaged!

Battery

	Description
Article	RMS-BAT (ER14505M, various manufacturers - see website: accessories)
Type	Li-SOCI2
Capacity	~2000 mAh
Voltage	3.6 V
Dimension	AA (H: 50.3mm, D: 14.55mm)

**IP Class**

IP65

RTCC (Real Time Clock Calendar)

The device is equipped with a real-time clock. The time is continuously synchronized if there is a connection to the server.

4.1.12 Accessories

Still under construction!